

Honeymoon House Trailer

From Popular Homecraft, March-April 1939

For Reference Only... Do not use to build a trailer.

Check on Teardrop and Tiny Travel Trailers for up to date building information;

<http://www.mikenchell.com/forums>

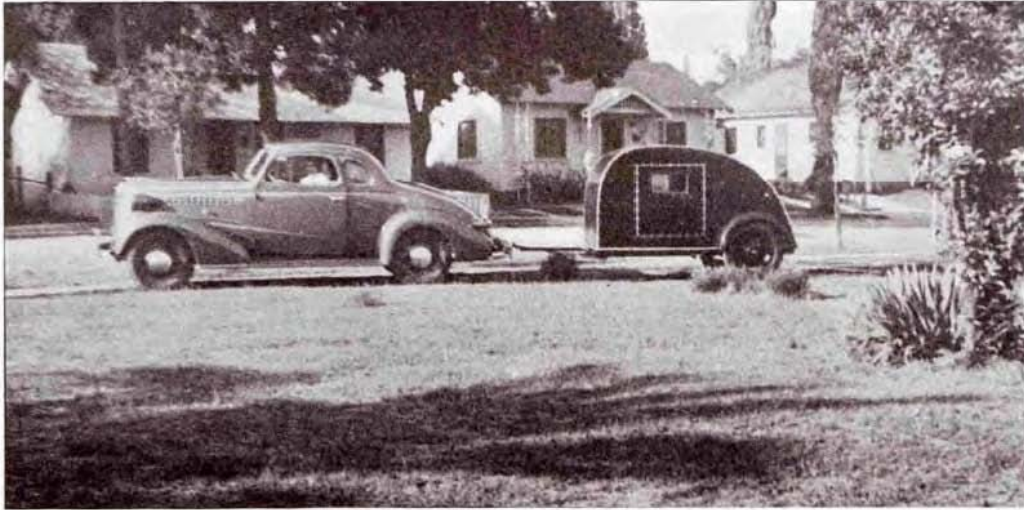

Note tiny proportions compared to modern car. The exterior is varnished.

"HONEYMOON HOUSE TRAILER"

BY HI SIBLEY

Built With Dimes; Total Cost \$60

THIS trim little trailer, designed and built by Louis Rogers of Pasadena for his wedding trip, has proved its practicability in long service on the road. Mr. Rogers pursued a unique method of saving the money for the material. Each time he changed a dollar bill he put any dimes received into a small bank, so that the trailer literally was built with dimes. Total cost for material was slightly over sixty dollars, and this modest investment was the result of many trips to various junk and wrecking yards. Odd pieces were picked up here and there, and the prospective builder of one like it should bear in mind that he need not use identical material if something different serves the purpose just as well. For instance, a tee-beam is used for the tow bar on the original, but an I-beam, or even a heavy timber can be used instead.

A Chevrolet front axle with 28 in. wheels was used in the Rogers trailer, the tie-rod being cut and bolted to the axle, as in Fig. 1. It is important that the wheels are properly aligned before drilling holes for the bolts. If you are equipped for the job, the ends of the tie-rod may be welded in place. Chassis frame is of pine two-by-fours with angle plates in the corners, secured with bolts. A cross member 18 in. back of the

front end carries one end of the tow bar, and a "wishbone" of 1" tubing reinforces the former in the manner illustrated. Sturdy strap iron x-braces give rigidity to the frame.

A caster-wheel bracket for supporting the tow bar when not attached to the car is made of flat bar iron as illustrated in Fig. 2. A 6" iron farm implement wheel is used in this case; any other wheel of about this size will be satisfactory. Note that two wing nuts are unscrewed to remove the caster from

the tow bar. Any standard trailer hitch is satisfactory for this job, and the chain required by some states can be secured to one of the bolts through the tow bar and two-by-four. Note that the wheels are set pretty well aft, making for smooth towing. Chevrolet 1926 fenders are installed, as this type does not require cutting into the body. The floor plan is just four by eight feet, and tongue-and-groove flooring is laid over the chassis frame. Screws instead of nails should be used



Trailer handles easily and turns in small space.

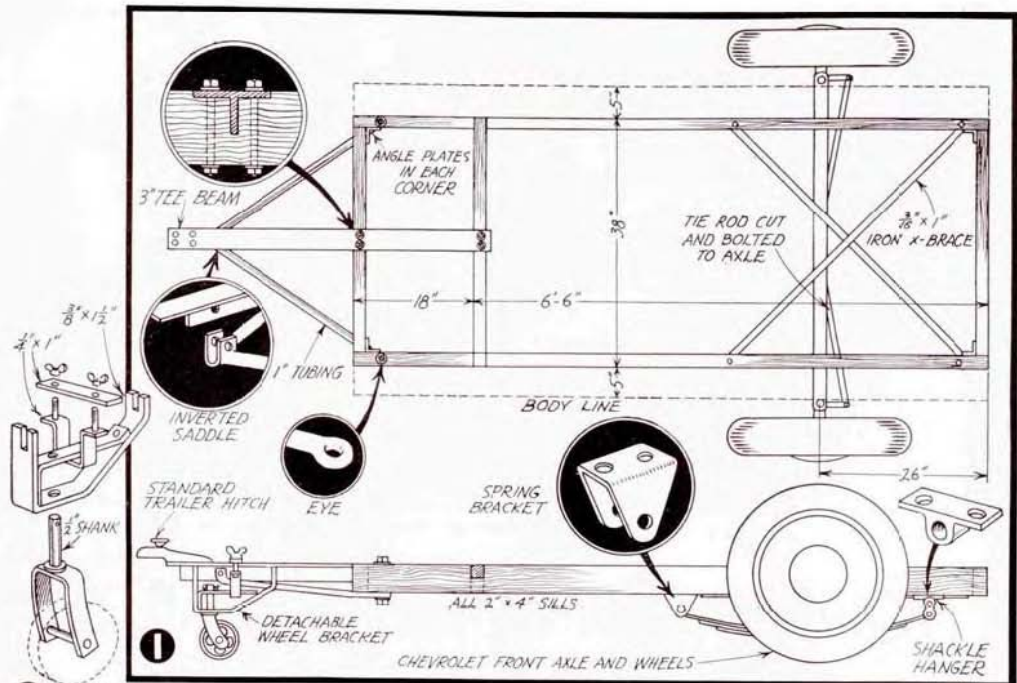

② 6" WHEEL

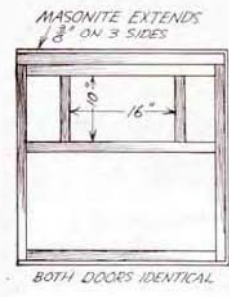

③

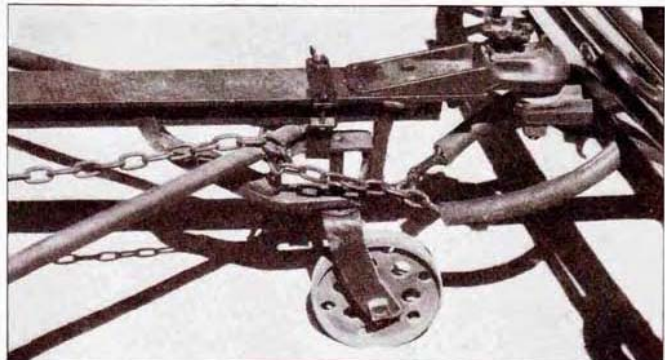
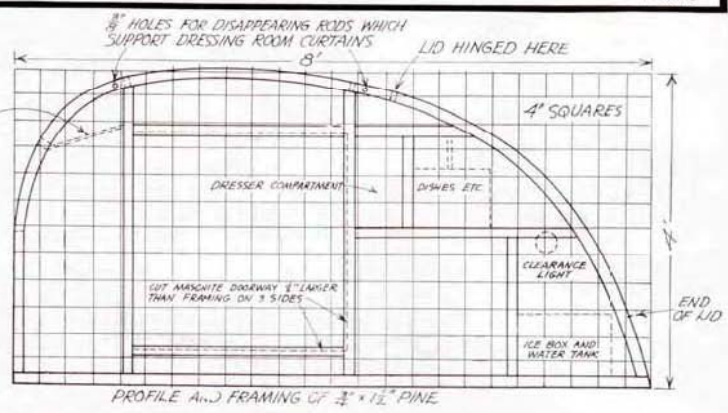

Removable caster for tow bar. (Used when disconnected from car.)

throughout in construction, and casein waterproof glue where applicable.

Profile of the side wall is given in Fig. 3, the squared diagram. This also gives location of various frame members. The doorway is cut slightly larger than the frame opening so that the edges of the door close against it. The cutaway perspective, Fig. 4, shows frame assembly. All framing is 3/4" by 1 1/2" pine, and tempered presdwood of 1/8" thickness is used for sheathing. It is secured to the framingwork with 3/4" No. 6 oval head screws and washers, spaced 5 1/2" apart. The

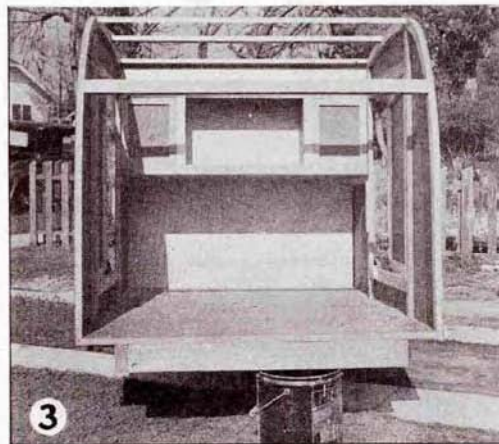

ceiling beams are notched into the side members as shown. Sides are each cut from a single panel 4 ft. by 8 ft., and are identical. A panel of the same size forms front end and roof, in one piece, and the lid over the kitchenette takes a panel 4 ft. by approximately 4 ft. 3 in. Below this is a removable panel of the same material.

Space for the mattress and springs is 6 ft. 4 in. long, and the bed must be installed before the rear partitions are put in. The partition above the ice box and water tank, however, is so constructed that it can be removed by taking out the screws, in case there is occasion to take out the bed. The joint at corner of roof and side wall is covered with aluminum or other metal moulding, secured with screws, as shown in the sectional drawing.

1 Incredible as it seems, this tiny trailer has 7³/₄" space in sleeping compartment, which extends from front end to upright frame member just behind the wheel. Framing is of 3/4" x 1 1/2" pine. Gussets are used on original, but plans are otherwise.

2 Frame work of lid over kitchenette. Note 1/4" plywood partitions under low shelf, water tank is installed at left, ice box at right. Louis Rogers, builder, demonstrating.

3 View looking aft, before roof is installed. Showing dresser with two side compartments. A mirror is to be set against the middle panel in back.

4 Sides and top are sheathed with hard pressed board 1/8" tempered presd-wood. No. 6 oval head screws, 3/4", with washers are spaced 5 1/2" apart.

The hinged lid over the kitchenette is shown in detail, Fig. 5. It is hinged at the top with standard butts, and a curved metal strip placed over the joint to keep out the rain. Two iron rods hold the lid up when open, and swing back under when closed. A rack is provided for the table. When in use the latter is supported on two paper-hanger's horses which have been cut down to 28 in. These fold up neatly and are stowed in the bin or compartment above the kitchenette. An automobile door handle with lock is used for the locking device fitted with two bars, as illustrated. There is a light under the lid, and on top, the tail light mounted on a strap iron bracket which also supports the license plate. Below the lid is a removable panel made as shown in Fig. 6. Three dowels in the bottom,

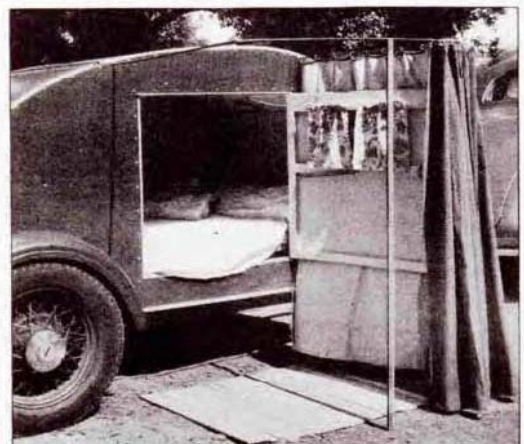
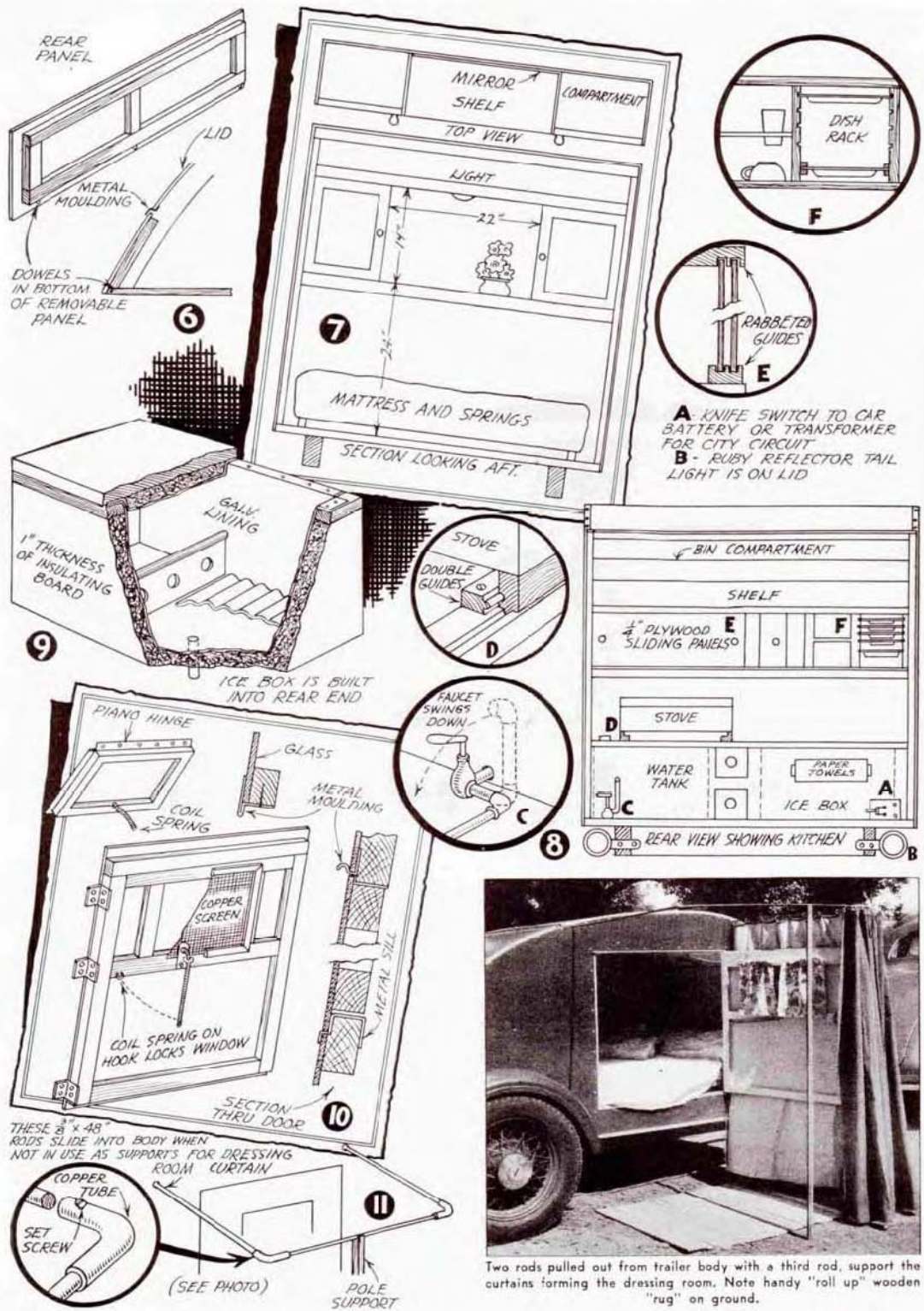

Two rods pulled out from trailer body with a third rod, support the curtains forming the dressing room. Note handy "roll up" wooden "rug" on ground.

set in holes in the floor, and the upper end is kept in place by the overlapping moulding of the lid.

Just at the rear end of the door a dresser is built in, Fig. 7, with two compartments with doors, and a mirror in back. A light is installed above. Note that the bed slides under this dresser, with ample body room between it and the bottom of the dresser to move about.

Dimensions of the kitchenette

full width of the trailer, suitable for curtains, table horses, etc.

The ice box is of galvanized iron insulated with two thicknesses of half-inch insulating board, and built into the trailer. Details are down in Fig. 9. The lid is also insulated, and when closed serves as a workbench for the cook. A $\frac{1}{4}$ " copper tube

drains direct to the ground, and a low partition prevents ice from sliding over onto the food adjoining.

It goes without saying that the cover must fit neatly and snugly.

As stated before, both doors are (Continued on page 488)



Mrs. [Lois] Rogers gets a jar from the ice box. At lower left note water faucet made from old gas light fixture parts.

compartments can be taken from the squared diagram, Fig. 3, and constructional details are shown in Fig. 8. At the bottom left is a built-in water tank, having a faucet that swings up out of the way of the lid when the latter is closed. Two drawers are provided, just to the left of center, and an ice box is built in on the right side. The stove slides out on wooden rails with grooves at right angles, preventing its shaking off when in motion. Above it are two panels sliding in rabbeted guides, and a dish compartment built to accommodate the dishes. The panels have brass finger-sockets to set in, and the guides should be sufficiently wide to prevent binding in damp weather. Give both the guides and edges of the plywood panels a thorough application of wax. In the dish rack, glasses set in holes in a shelf, and rabbeted grooves take care of the plates. Above this is a bin the

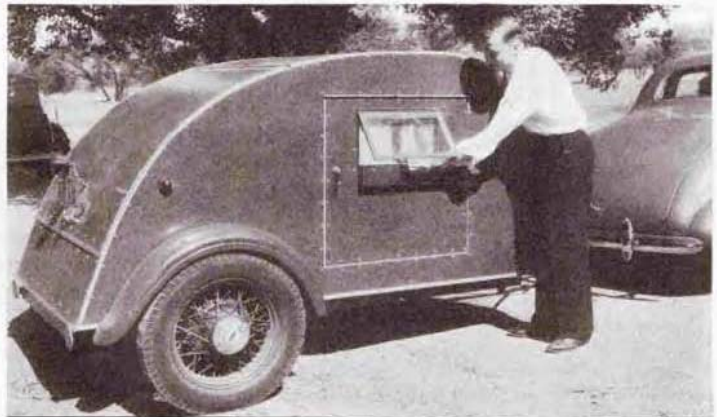
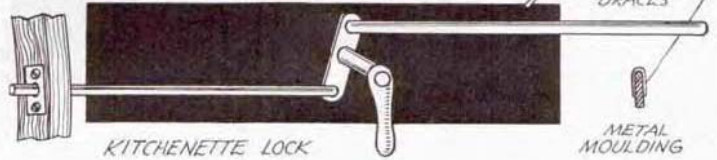
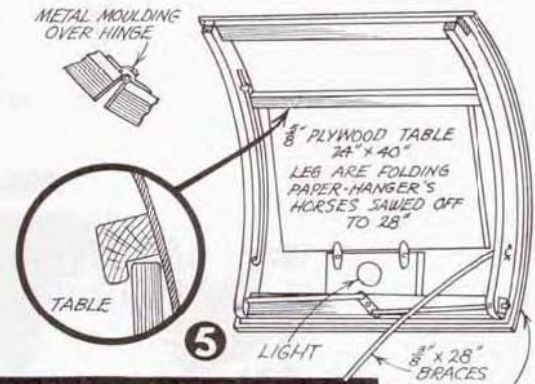

Louis Rogers of Pasadena, designer and builder, demonstrates the novel window bracket. Normally, it is worked from the inside.

WATSON INDEPENDENT LATHE CHUCK
New Model "B"
 The Most Practical Chuck for Home Workshop Lathe Work
A REAL VALUE
 Drop Forged Reversible Jaws. Acme Thread Screws. Jaws and Screws Hardened.
FULL GUARANTEE
 An additional charge is made for Adapter Plates or Bushings, where required.
 ASK YOUR DEALER or write us direct. Chuck sent postpaid on receipt of price or send \$1 and pay balance on delivery.
THE WATSON MFG. CO.
 470 Watson Bldg. Toledo, Ohio, U. S. A.



3 in. \$4.00
 4 in. \$5.00
 6 in. \$9.50
 8 in. \$17.50

NEW CARPENTRY BOOK
Modern Carpentry
 This work on carpentry is the most practical and complete ever published. Shows how to lay out roofs, rafters, stairs, ladders, boards of all kinds, water-tight joints, single work, flooring, spliced work, plate marks and hand-railing, partition, dovetailing and many other things the carpenter will require to know. Written in a very simple style and can be understood readily. See Page 600 (1/25) on cover.
\$2.00
FREE Considerable amount of practical hints on Painting, Interior, Commercial Art, Sheet Metal, Welding, Building, Electrical, Engineering, Carpentry and Building, Plumbing, Heating and Ventilating. WRITE TODAY.
FREDERICK J. DRAKE & CO.
 183 N. Michigan Ave. CHICAGO



WRITE TODAY REDIKIT
 for our NEW CATALOG on KNOCK-DOWN FURNITURE and SUPPLIES. Enclose 10c in coin.
GEISER BROS.
 323 Cherry St., Dover, Ohio

BEAUTIFUL PICTURE In Natural Color
Made From Veneer Kits
 Complete Kit "Moonlight" as illustrated. The finished, one-of-a-kind picture, ready to hang. Craftsmanship work. Try it. Kit at this introductory price.
JOHN W. HOUGH
 143 W. 107th St., Chicago, Ill.
 Representing: Multicolor, Ltd., Deventer, Holland.



3 IN 1 Electric TORCH
WELDS BRAZES SOLDERS
 Now, an electric welding, brazing and soldering torch complete with built-in power unit, goggles and supplies. Works instantly off any light socket. Does a thousand and one repair jobs at an amazingly low cost on aluminum, iron, steel and other metals. Indispensable in auto shops for fender and body repairs. Unobtainable for home repairs, shop, factory, farm engineer, janitor, sheet metal, radio and bicycle repairs. Any one can handle without previous experience with any electrical equipment. Guaranteed material and construction job.
10-DAY HOME TRIAL
 For 10 days at our risk or get one without a cent by returning to us the original price.
ELECTRO-TORCH CO.
 2013 CT Michigan Ave., Chicago



BIRD TOWERS
ESPECIALLY DESIGNED FOR MARTINS
 Be the first in your neighborhood to erect a modern, stream-lined Martin Tower. Here is a proven design for an eight compartment house that is sure to attract the birds and will be an ornament in any garden. Many now in use from coast to coast. All dimensions are worked out according to U. S. Bird Bulletins. You can easily build this tower in your own workshop when you have my plans and instructions, as well as full sized patterns for all pieces required. Get started now. Be sure to have your house up before the birds arrive. For complete packet send \$1 bill or money order to
CHANDLER MURPHY
 4590 W. Lake Harriet Blvd.
 Minneapolis, Minnesota

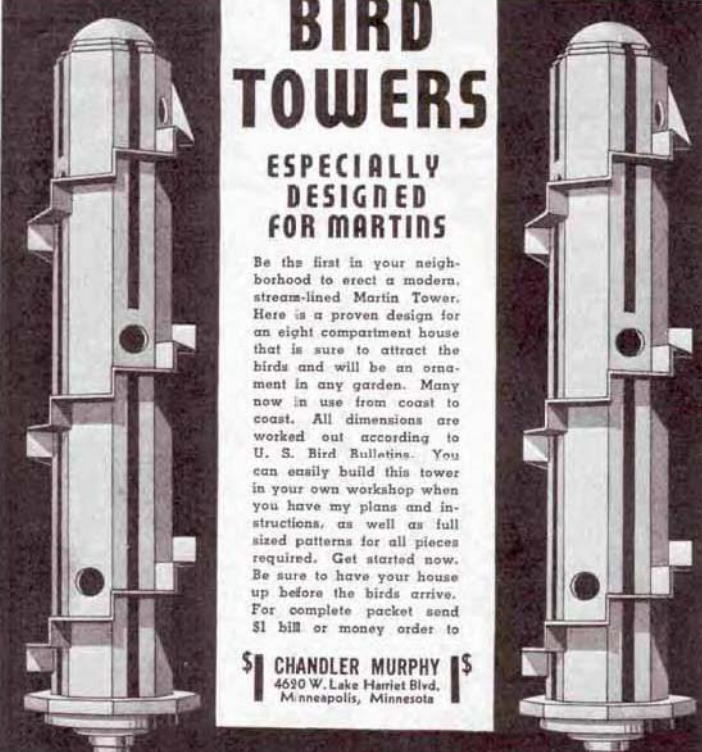

upon the kinds of solvents and diluents which are placed in the lacquers by the manufacturers. Lacquers dry entirely by evaporation of the solvents and diluents which may be varied in order to secure very fast or rather slow drying. Undercoats containing linseed oil especially are not now used under lacquers by experienced finishers. Fillers and varnishes contain linseed oil usually and are not fit for undercoats for lacquers.

"HONEYMOON HOUSE TRAILER"
 (Continued from page 451)

identical, but one is fitted with a Yale lock, and the other fastened from the inside with an icebox handle taken from an old refrigerator. Construction of the door is shown in Fig. 10 and Mr. Rogers has devised a very ingenious window fastener and bracket combined. This consists simply of a coiled screen-door spring passing through two eyes set at right angles, as in Fig. 10. By pushing the spring out through the eyes it opens the window from the inside and holds it in any position. When closed, the end of the spring is put on a hook at one side, making an effective lock. The spring passes through a hole in the copper screen. The window is hinged at the top with a piano hinge, and the glass is held by a frame made of galvanized sheet iron bent as shown in the sectional drawing, and mitted and soldered at the corners. Painted over brown of the same shade as the sheathing of the trailer, it makes a neat appearance.

Aluminum moulding is placed over the door sill, with a small cavestrough of the same material above the door, as shown in the sectional drawing. In forming these pieces as well as all other sheet metal work it will be necessary, for a neat job, to have your local tinsmith do the work with his shop equipment. It shouldn't cost much.

With a trailer of these compact dimensions, dressing is best done outside, and Mr. Rogers has rigged up a very satisfactory dressing room at the door with a curtain. This is supported on two rods which slide out from the top of the body on either side of the door, Fig. 11, and are just 4' long, the width of the trailer. A third rod, fitted with sockets at each end made of copper tubing, joins the other two and is held up by a wooden pole. Curtains strung along this make a very satisfactory dressing room, especially when a wood floor is provided. This last (see photo) is made of Venetian slats something on the order of Venetian blinds and can be rolled up and stowed in small space.

Lighting on Mr. Roger's trailer is from the car battery, but one could be put in the trailer itself independent of the car. There are six bulbs installed, one under the shelf at the forward end of the sleeping compartment, one over the dresser, one under the kitchenette lid, one tail light and two blue clearance lights. A knife switch is provided to throw on current from car battery, or switch over to city 110-v circuit through a transformer.